

# SERVICE MANUAL

## EH215 CRAWLER EXCAVATOR

6-75780NA



**NEW HOLLAND**  
**CONSTRUCTION**

# **SERVICE MANUAL**

## **EH215 CRAWLER EXCAVATOR**



**NEW HOLLAND CONSTRUCTION**

---

Form Number 6-75780NA-NH

Any use of editorial or pictorial content is strictly prohibited without express written permission from  
CNH America LLC. Carol Stream, IL 60188 U.S.A.  
Copyright © 2004 CNH America LLC. All Rights Reserved.  
Issued January, 2004 - Form Number 6-75780NA-NH00  
Source Code No. S5YQ/LL12E-00

# EH215 CRAWLER EXCAVATOR

## NEW HOLLAND CONSTRUCTION

### TABLE OF CONTENTS

#### SECTION 1 -SPECIFICATIONS

Chapter 01	Safety.....	6-75780NA-NH01
Chapter 02	Transportation .....	6-75780NA-NH02
Chapter 03	Specifications.....	6-75780NA-NH03
Chapter 04	Attachment Dimensions.....	6-75780NA-NH04

#### SECTION 2 -MAINTENANCE

Chapter 11	Tools.....	6-75780NA-NH11
Chapter 12	Standard Maintenance Time Table.....	6-75780NA-NH12
Chapter 13	Maintenance Standard and Test Procedures.....	6-75780NA-NH13

#### SECTION 3 -SYSTEM

Chapter 21	Mechatrol Control System.....	6-75780NA-NH21
Chapter 22	Hydraulic System .....	6-75780NA-NH22
Chapter 23	Electrical System .....	6-75780NA-NH23
Chapter 24	Components System .....	6-75780NA-NH24
Chapter 25	Air Conditioner System .....	6-75780NA-NH25

#### SECTION 4 -DISASSEMBLY AND ASSEMBLY

Chapter 31	Disassembly and Assembly .....	6-75780NA-NH31
Chapter 32	Attachments .....	6-75780NA-NH32
Chapter 33	Upper Structure .....	6-75780NA-NH33
Chapter 34	Travel System.....	6-75780NA-NH34

#### SECTION 5 -TROUBLESHOOTING

Chapter 41	Mechatro Control (Troubleshooting).....	6-75780NA-NH41
Chapter 42	Hydraulic System (Troubleshooting) .....	6-75780NA-NH42
Chapter 43	Electrical System (Troubleshooting).....	6-75780NA-NH43
Chapter 44	Engine (Troubleshooting) .....	6-75780NA-NH44

#### SECTION 6 -ENGINE

Chapter 51	Engine .....	6-75780NA-NH51
------------	--------------	----------------

## NOTES

**CHAPTER 1**

**NEW HOLLAND EH215**

**SAFETY**



**TABLE OF CONTENTS**

1.1 GENERAL SAFETY INFORMATION .....1.1  
1.2 SAFETY PRECAUTIONS .....1.2

Any use of editorial or pictorial content is strictly prohibited without express written permission from  
CNH America LLC. Carol Stream, IL 60188 U.S.A.  
Copyright © 2004 CNH America LLC. All Rights Reserved.  
Issued January, 2004 - Form Number 6-75780NA-NH01  
Source Code No. S5YQ/LL0112E-00

## SAFETY PRECAUTIONS

### 1.1 GENERAL SAFETY INFORMATION

 <b>WARNING</b> 
<p>Do Not operate or perform any maintenance on this machine until all instructions found in the OPERATION'S MANUAL have been thoroughly read and understood.</p> <p>Improper operation or maintenance of this machine may cause accidents and could result in serious injury or death.</p> <p>Always keep the manual in the operator's seat pocket.</p> <p>If it is missing or damaged, place an order with an authorized Distributor for a replacement.</p> <p>If you have any questions, please consult an authorized Distributor.</p>

1. Most accidents, which occur during operation, are due to neglect of precautionary measures and safety rules. Sufficient care should be taken to avoid these accidents. Erroneous operation, lubrication or maintenance services are very dangerous and may cause injury or death of personnel. Therefore all precautionary measures, NOTES, DANGERS, WARNINGS and CAUTIONS contained in this manual and on the machine should be read and understood by all personnel before starting any work with or on the machine.
2. Operation, inspection, and maintenance should be carefully carried out, and safety must be given the first priority. Messages of safety are indicated with marks. The safety information contained in this manual is intended only to supplement safety codes, insurance requirements, local laws, rules and regulations.
3. Messages of safety appear in this manual and on the machine. All messages of safety are identified by the words DANGER, WARNING and CAUTION.
  - a. **DANGER** – Indicates an imminently hazardous situation which, if not avoided, will result in death or serious injury and is represented as follows:

 <b>DANGER</b> 
---



- b. **WARNING** – Indicates a potentially hazardous situation which, if not avoided, could result in death or serious injury and is represented as follows:

 <b>WARNING</b> 
--

- c. **CAUTION** – Indicates a potentially hazardous situation which, if not avoided, may result in minor or moderate injury. It may also be used to alert against possible damage to the machine and its components and is represented as follows:

 <b>CAUTION</b> 
--

4. It is very difficult to forecast every danger that may occur during operation. However, safety can be ensured by fully understanding proper operating procedures for this machine according to methods recommended by the manufacturer.
5. While operating the machine, be sure to perform work with great care, so as not to damage the machine, or allow accidents to occur.
6. Continue studying this manual until all Safety, Operation and Maintenance procedures are completely understood by all persons working with the machine.

 <b>WARNING</b> 
<p>The proper and safe lubrication and maintenance for this machine, recommended by the manufacturer, is outlined in the OPERATOR'S MANUAL for this machine.</p> <p>Improper performance of lubrication or maintenance procedures are dangerous and could result in injury or death. Read and understand the OPERATOR'S MANUAL before performing any lubrication or maintenance.</p>



## SAFETY PRECAUTIONS

### 1.2 SAFETY PRECAUTIONS

The serviceman or mechanic may be unfamiliar with many of the systems on this machine. This makes it important to use caution when performing service work. A knowledge of the system and or components is important before the removal or disassembly of any component.

Because of the size of some of the machine components, the serviceman or mechanic should check the weights noted in this manual. Use proper lifting procedures when removing any components. Weight of components table is shown in chapter SPECIFICATIONS in this manual.

The following is a list of basic precautions that must always be observed.

1. Read and understand all warning plates and decals on the machine before operating, maintaining or repairing this machine.
2. Always wear protective glasses and protective shoes when working around machines. In particular, wear protective glasses when using hammers, punches or drifts on any part of the machine or attachments. Use welders gloves, hood/goggles, apron and the protective clothing appropriate to the welding job being performed. Do not wear loose fitting or torn clothing. Remove all rings from fingers, loose jewelry, confine long hair and loose clothing before working on this machinery.
3. Disconnect the battery and hang a "Do Not Operate" tag in the operator's compartment. remove ignition keys.
4. If possible, make all repairs with the machine parked on a level, hard surface. Block the machine so it does not roll while working on or under the machine. Hang a "Do Not Operate" tag in the operator's compartment.
5. Do not work on any machine that is supported only by lift, jacks or a hoist. Always use blocks or jack stands, capable of supporting the machine, before performing any disassembly.
6. Relieve all pressure in air, oil or water systems before any lines, fittings or related items are disconnected or removed. Always make sure all raised components are blocked correctly and be alert for possible pressure when disconnecting any device from a system that utilizes pressure.
7. Lower the bucket, blade or other attachments to the ground before performing any work on the machine. If this cannot be done, make sure the bucket, blade or other attachment is blocked correctly to prevent it from dropping unexpectedly.
8. Use steps and grab handles when mounting or dismounting a machine. Clean any mud, grease, oil or debris from steps, walkways or work platforms before using. Always face the machine when using steps, ladders and walkways. When it is not possible to use the designed access system, provide ladders, scaffolds, or work platforms to perform safe repair operations.
9. To avoid back injury, use a hoist when lifting components which weigh 23 kg (50 lbs) or more. Make sure all chains, hooks, slings, etc., are in good condition and are the correct capacity. Be sure hooks are positioned correctly. Lifting eyes are not to be side loaded during a lifting operation.
10. To avoid burns, be alert for hot parts on machines which have just been stopped and hot fluids in lines, tubes and components.
11. Be careful when removing cover plates. Gradually back off the last two bolts or nuts located at opposite ends of the cover or device and carefully pry cover loose to relieve any spring or other pressure, before removing the last two bolts or nuts completely.
12. Be careful when removing filler caps, breathers and plugs on the machine. Hold a rag over the cap or plug to prevent being sprayed or splashed by liquids under pressure. The danger is even greater if the machine has just been stopped because fluids can be hot.
13. Always use the proper tools that are in good condition and that are suited for the job at hand. Be sure you understand how to use them before performing any service work.
14. Reinstall all fasteners with the same part number. Do not use a lesser quality fastener if replacements are necessary.



### WARNING



Do not operate this machine unless you have read and understand the instructions in the OPERATOR'S MANUAL. Improper machine operation is dangerous and could result in injury or death.

## SAFETY PRECAUTIONS

15. Repairs which require welding should be performed only with the benefit of the appropriate reference information and by personnel adequately trained and knowledgeable in welding procedures. Determine type of metal being welded and select correct welding procedure and electrodes, rods or wire to provide a weld metal strength equivalent at least to that of the parent metal. Make sure to disconnect battery before any welding procedures are attempted.
16. Do not damage wiring during removal operations. Reinstall the wiring so it is not damaged nor will be damaged in operation of the machine by contacting sharp corners, or by rubbing against some object or hot surface. Do not connect wiring to a line containing fluid.
17. Be sure all protective devices including guards and shields are properly installed and functioning correctly before starting a repair. If a guard or shield must be removed to perform the repair work, use extra caution and replace the guard or shield after repair is complete.
18. The maintenance and repair work while holding the bucket raised is dangerous due to the possibility of a falling attachment. Don't fail to lower the attachment and place the bucket to the ground before starting the work.
19. Loose or damaged fuel, lubricant and hydraulic lines, tubes and hoses can cause fires. Do not bend or strike high pressure lines or install ones which have been bent or damaged. Inspect lines, tubes and hoses carefully. Do not check for leaks with your hands. Very small (pin hole) leaks can result in a high velocity oil stream that will be invisible close to the hose. This oil can penetrate the skin and cause personal injury. Use cardboard or paper to locate pin hole leaks.
20. Tighten connections to the correct torque. Make sure that all heat shields, clamps and guards are installed correctly to avoid excessive heat, vibration or rubbing against other parts during operation. Shields that protect against oil spray onto hot exhaust components in event of a line, tube or seal failure must be installed correctly.
21. Do not operate a machine if any rotating part is damaged or contacts any other part during operation. Any high speed rotating component that has been damaged or altered should be checked for balance before reusing.
22. Be careful when servicing or separating the tracks. Chips can fly when removing or installing a track pin. Wear safety glasses and long sleeve protective clothing. Tracks can unroll very quickly when separated. Keep away from front and rear of machine. The machine can move unexpectedly when both tracks are disengaged from the sprockets. Block the machine to prevent it from moving.

## NOTES

# NEW HOLLAND EH215

## TRANSPORTATION

Any use of editorial or pictorial content is strictly prohibited without express written permission from  
CNH America LLC. Carol Stream, IL 60188 U.S.A.

Copyright © 2004 CNH America LLC. All Rights Reserved.

Issued January, 2004 - Form Number 6-75780NA-NH02

Source Code No. S5YQ/LL0212E-00

## TABLE OF CONTENTS

A. GROUND TRANSPORTATION .....	2
1. Machine Preparation.....	2
2. Loading the Machine.....	3
2. Securing Machine to Traylor.....	4
B. LIFTING MACHINE.....	4
1. Lifting Machine With Attachment Installed .....	4
2. Lifting Machine Without Attachment.....	8
C. SHIPPING DIMENSIONS.....	11
1. SK210(LC)-VI - Figure 5-10A & 5-10B.....	11
a. Machine With Standard Attachments.....	10
b. Boom With Arm Cylinder - Figure 5.10C .....	11
c. Arm With Bucket Cylinder - Figure 5.11A .....	12
d. Arm With Bucket Cylinder and Bucket - Figure 5.11B.....	12
e. Bucket - Figure 5.11C .....	12
2. SK250(LC)-VI - Figure 5-12A & 5-12B.....	13
a. Machine With Standard Attachments.....	13
b. Boom With Arm Cylinder - Figure 5.12C .....	13
c. Arm With Bucket Cylinder - Figure 5.13A.....	14
d. Arm With Bucket Cylinder and Bucket - Figure 5.13B.....	14
e. Bucket - Figure 5.13C .....	14

## A. GROUND TRANSPORTATION

### 1. Machine Preparation

- Know the total weight, length, width and height of the machine being transported. See Figures 5.2A and 5.2B.
- Know route to be traveled. Investigate bridges, overpasses, height of road signs on route.

- Obtain any permits required from proper government agencies for machine transportation.
- Use only a trailer with a rated capacity sufficient to transport the machine.
- Make certain trailer has ramps or a ramp is available for loading and unloading the machine.

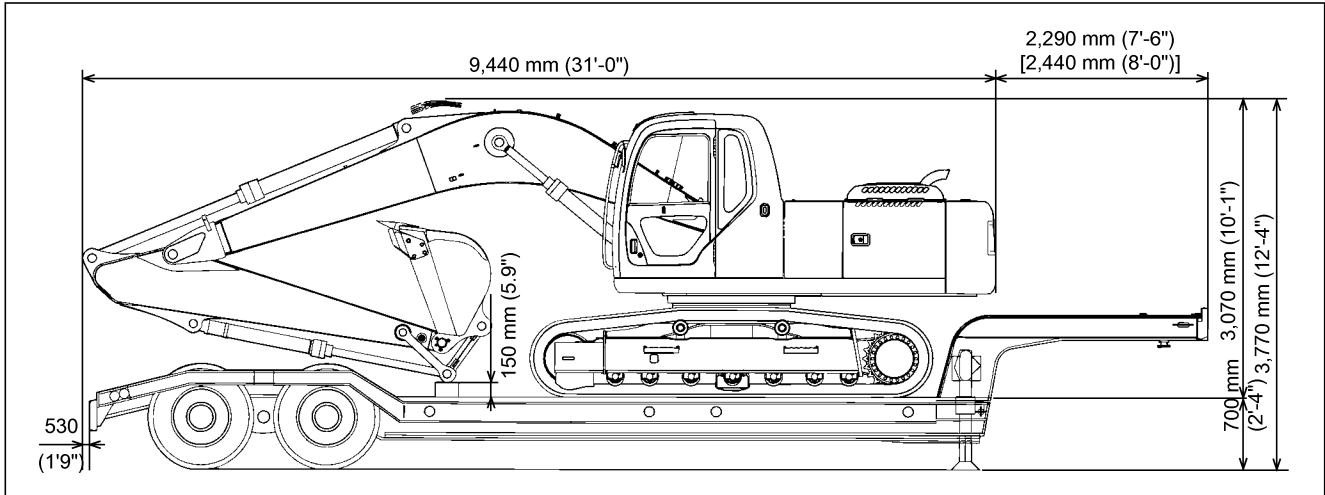

FIGURE 5.2A

Dimensions and weights are with 2.94 m (9'-8") arm, 0.81 m<sup>3</sup> (1.06 yrd<sup>3</sup>) bucket and 5.65 m (18'-6") boom.

**Note:** This illustration is for demonstration purposes only. Always, make sure to check actual dimensions after machine is loaded on trailer.

SHOES	600 mm (23.6")	700 mm (27.6")	800 mm (31.5")	900 mm (35.4")
MODEL				
SK210-VI	20,000 (44,090)	--	--	--
SK210LC-VI	20,500 (45,200)	21,000 (46,300)	21,300 (47,000)	21,500 (47,400)

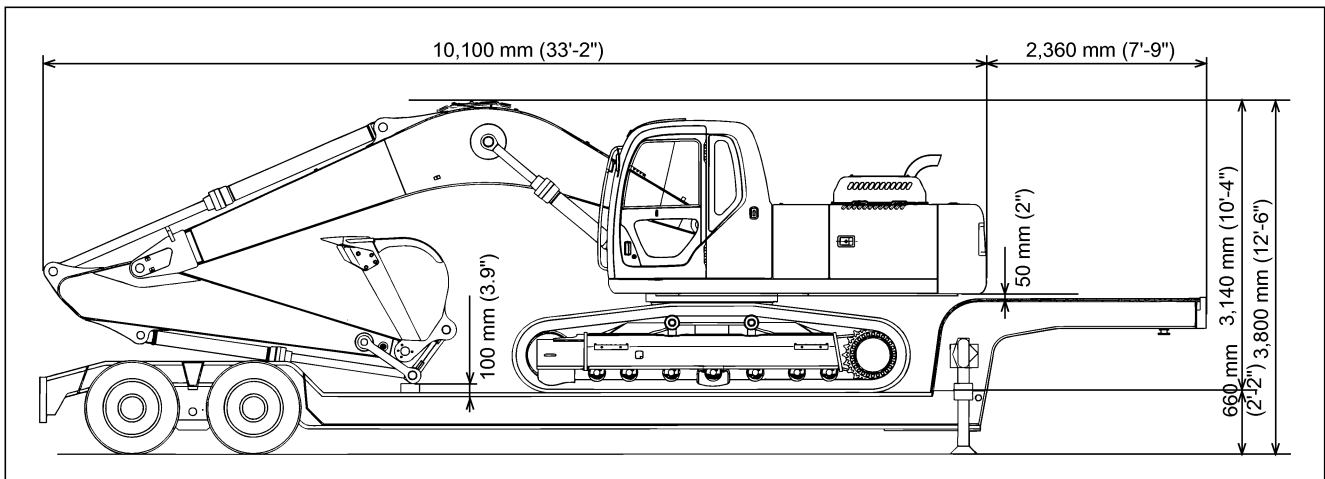

FIGURE 5.2B

Dimensions and weights are with 2.98 m (9'-9") arm, 1.04 m<sup>3</sup> (1.36 yrd<sup>3</sup>) bucket and 6.02 m (19'-9") boom.

**Note:** This illustration is for demonstration purposes only. Always, make sure to check actual dimensions after machine is loaded on trailer.

SHOES	600 mm (23.6")	800 mm (31.5")	900 mm (35.4")
MODEL			
SK250-VI	23,600 (52,000)	--	--
SK250LC-VI	24,200 (53,350)	24,800 (54,700)	25,100 (55,300)



## WARNING



Never attempt to load or unload machine without ramps.

### 2. Loading the Machine

- Apply parking brakes on tractor and trailer and chock trailer wheels before attempting to load or unload machine.
- Lower ramps of trailer.
- Place travel speed select switch on travel lever in 1st (**SLOW**) speed position and move throttle control to the **LO** idle position. See Figure 5.3A.
- Slowly travel machine up trailer ramps and over rear axles of trailer.
- Slowly travel machine completely onto trailer until in proper transport position.
- Slowly swing machine 180° until attachment is toward rear of trailer.
- Slowly lower boom until attachment rests on trailer bed.
- Place safety lock lever in the up “LOCKED” position. See Figure 5.3C.
- Turn machine “OFF”, remove key and lock all doors, filler caps and access panels.

Place a cover over the exhaust pipe of the machine and secure to avoid water entering the engine, and possible turbo damage.

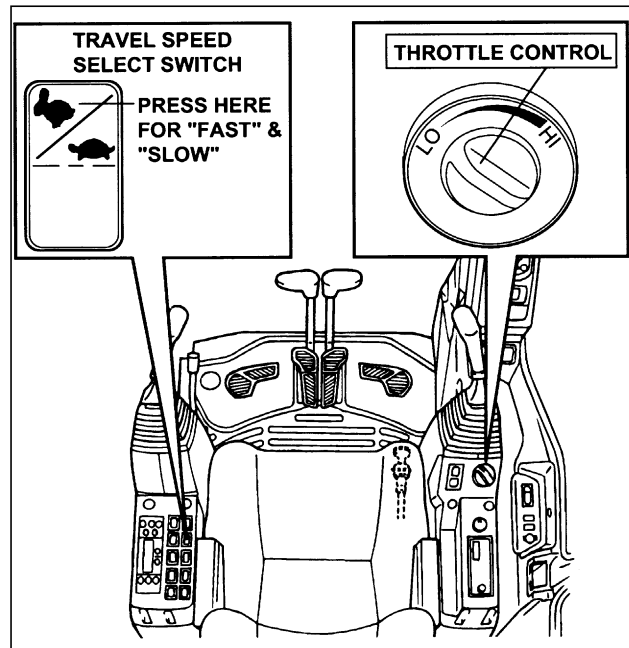
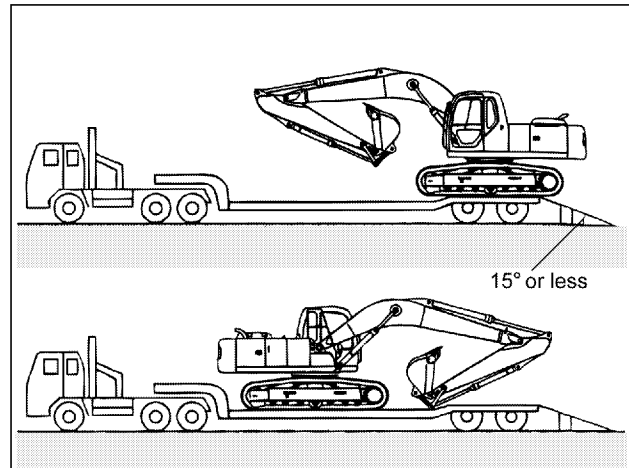

FIGURE 5.3A



## WARNING



Do not try to load machine without attachment in this type of trailer. Machine could tip over. This illustration is for demonstration only.

FIGURE 5.3B



## WARNING



To prevent the arm and bucket cylinder(s) from any damage, you are advised to follow the following instructions. Do not have the arm and/or bucket cylinder fully extended to a “ramp over center” situation. This allows sudden and abrupt contact of the arm or bucket to a trailer deck, ramp or the ground. This can result in internal mechanical contact, which can stretch the cylinder rod(s).



## CAUTION



Put a cover over the exhaust pipe of the machine to keep water from entering the engine and possible turbo damage.

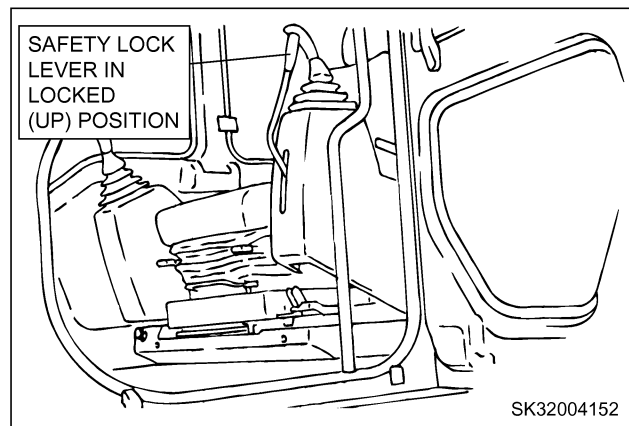

SK32004152

FIGURE 5.3C



### 3. Securing Machine to Trailer

- a. Use cable or wire rope with sufficient capacity to secure front and rear of the machine to trailer. See Figure 5.4A. Chock the tracks, use the lower frame front and rear brackets to secure machine to trailer. Also, make sure to secure front and rear of each track.
- b. Securely fasten all loose parts, as well as removed parts to trailer or transporting platform.

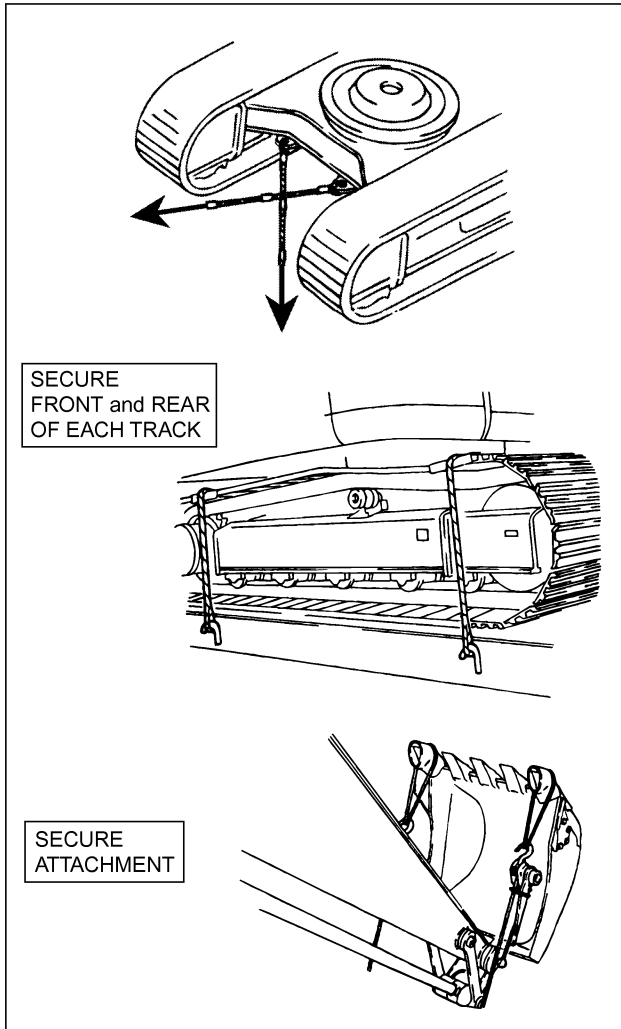

SECURE  
FRONT and REAR  
OF EACH TRACK

SECURE  
ATTACHMENT

FIGURE 5.4A

SK32004153

### B. LIFTING MACHINE

The following procedures are for lifting the machine, as built by the manufacturer. These procedures do not take into account modifications made to the machine that affect machine weight or center of gravity.

#### 1. Lifting Machine With Attachment Installed

- a. Locate lifting locations at the front and rear of each crawler frame. See Figure 5.4B.
- b. Attach cables or wire rope with a capacity rating sufficient to lift the machine, at lifting locations..

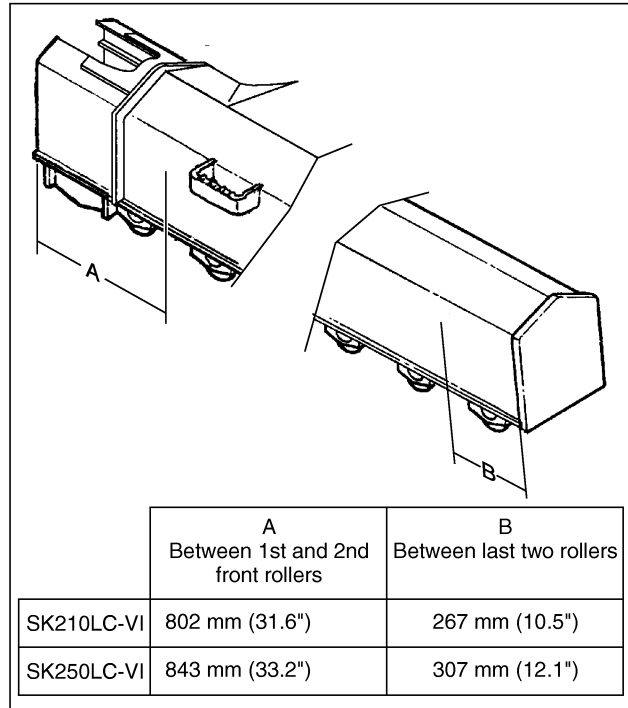

FIGURE 5.4B



### CAUTION



Place a hardwood or steel block between cables and crawler frame to prevent damage to the tracks from cables during lifting. See Figure 5.4C

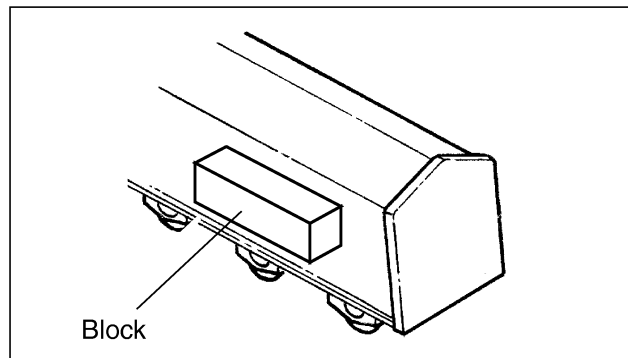

FIGURE 5.4C

- c. Bring loose ends of cables together at machine center of gravity and attach to an overhead lifting device with a rated lifting capacity sufficient to lift the machine. See Figure 5.5A to 5.7A.

**NOTE:** It may be necessary to place reinforced spreader bars between lifting cables to prevent damage to the machine during lifting. See Figures 5.5A to 5.7A.

**IMPORTANT:** Lifting machine with wider track shoes will tend to shift the Center of Gravity slightly forward, toward the center of the slewing ring.

**! DANGER !**

Always use proper lifting equipment and devices. Use of improper lifting equipment could allow the load to shift or fall causing severe damage, serious injury or death.

**! WARNING !**

Do not use the counterweight lifting eyes to lift machine.

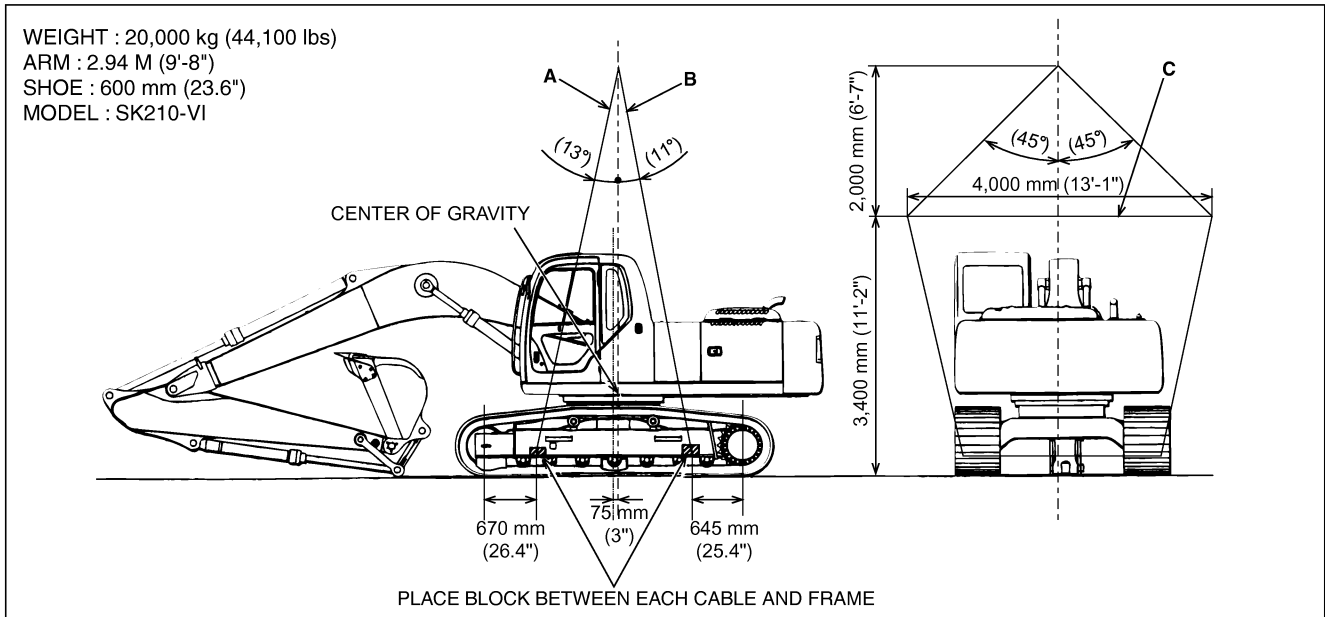

FIGURE 5.5A

- A. One 33.5 x 15.0 m Cable B. One 33.5 x 14.9 m Cable C. Two 4.0 m Spreader Bars

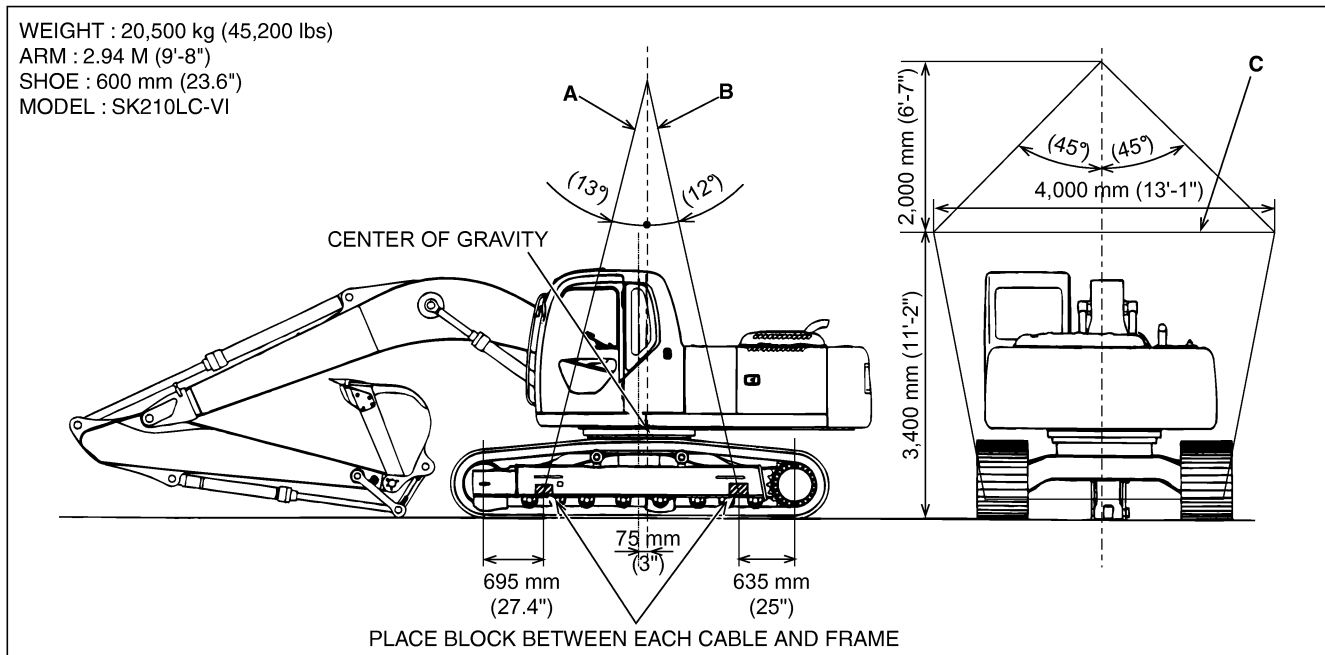

FIGURE 5.5B

- A. One 33.5 x 15.2 m Cable B. One 33.5 x 15.1 m Cable C. Two 4.0 m Spreader Bars



# DANGER



Always use proper lifting equipment and devices. Use of improper lifting equipment could allow the load to shift or fall causing severe damage, serious injury or death.



# WARNING



Do not use the counterweight lifting eyes to lift machine.

**IMPORTANT:** Lifting machine with wider track shoes will tend to shift the Center of Gravity slightly forward, toward the center of the slewing ring.

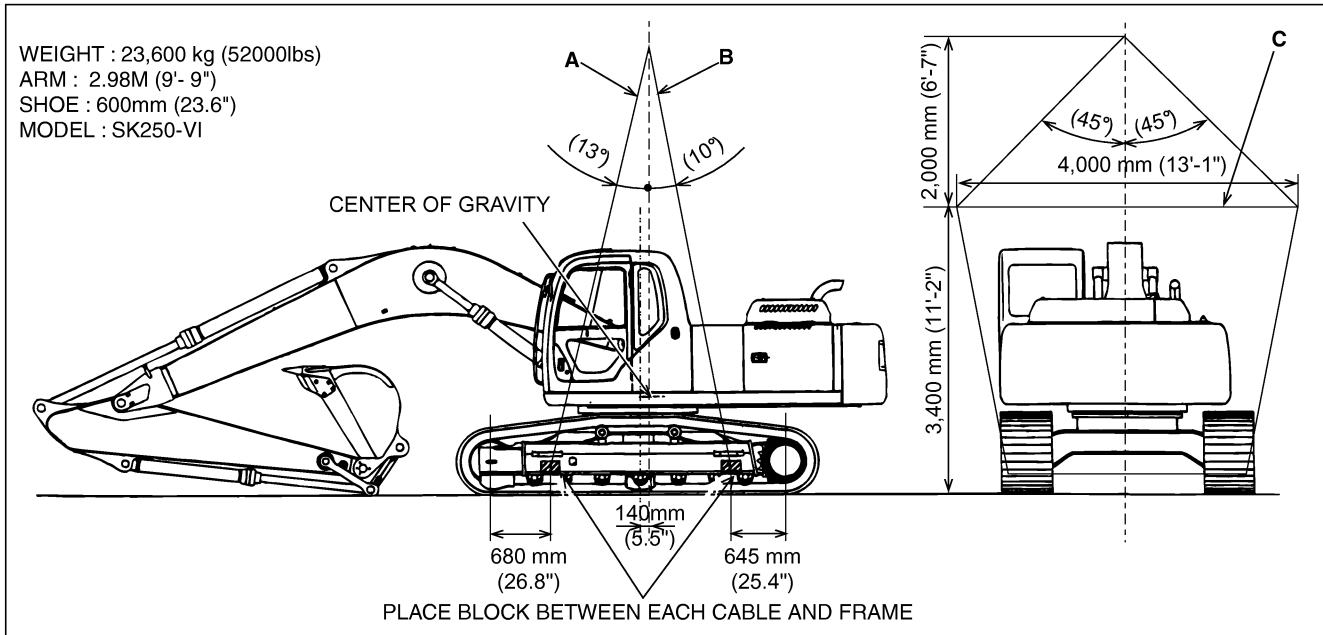

FIGURE 5.6A

A. One 37.5 x 15.2 m Cable B. One 37.5 x 15.1 m Cable C. Two 4.0 m Spreader Bars

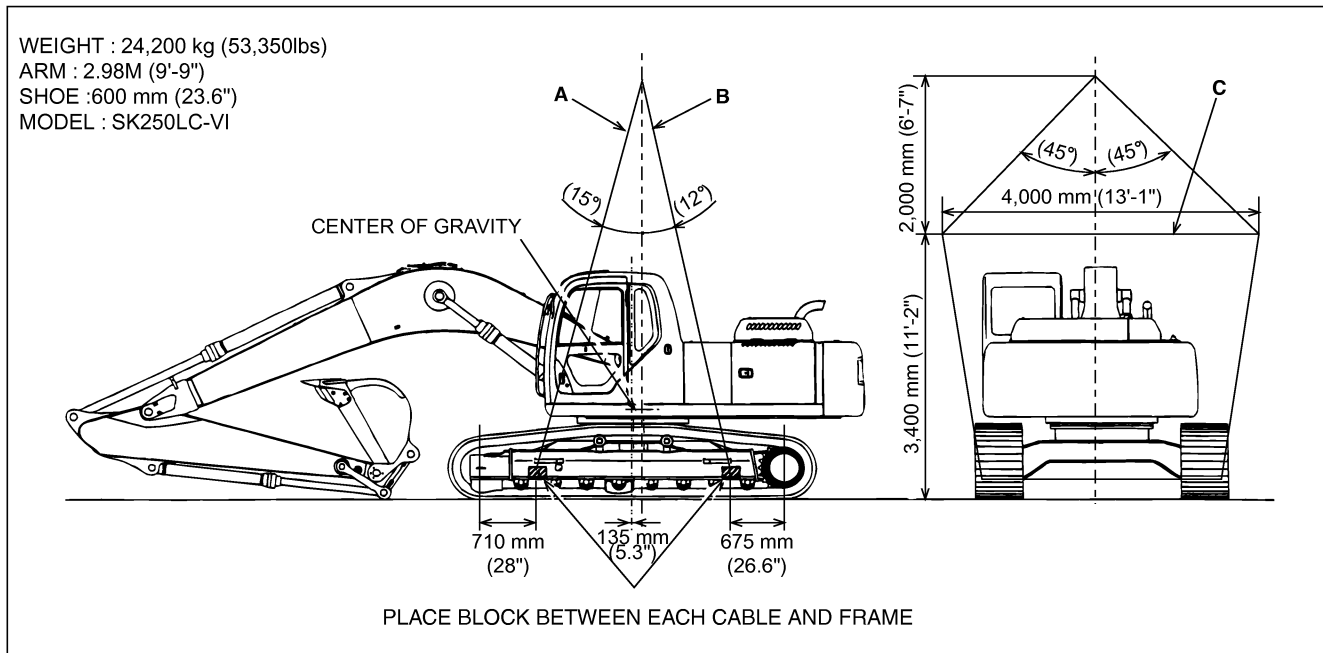

FIGURE 5.6B

A. One 37.5 x 15.5 m Cable B. One 37.5 x 15.3 m Cable C. Two 4.0 m Spreader Bars

**Thanks very much for your reading,  
Want to get more information,  
Please click here, Then get the complete  
manual**

**JustClickHere** 

**NOTE:**

**If there is no response to click on the link above,  
please download the PDF document first, and then  
click on it.**

**Have any questions please write to me:  
[admin@servicemanualperfect.com](mailto:admin@servicemanualperfect.com)**